



Innovative pet food solutions



coperion.com/fhn

A higher standard of pet food production

Pet food and human food may be different, but the needs and expectations are the same: quality, consistency, safety and nutrition.

Whether it's gentle, food-safe pneumatic conveying that minimizes finished product degradation and breakage, or filters, feeders, mills, sifters and airlocks designed for easy cleaning ensuring hygiene. Attention to the outcome is a hallmark of Coperion pet food manufacturing solutions.



Confidence through partnership

Coperion and its brands, with over 200 years of expertise, proudly deliver solutions that help shape how the world eats, nourishes, and heals.



Turnkey process solutions for pet food



High-tech solutions for bulk material handling systems

Precisely handled bulk materials are critical to the manufacture of the highest quality pet food brands. Our adaptable high-tech solutions are specially designed for the demands of the most stringent branded pet foods.

Whether you need a gravimetric feeder for dosing digest, weighbelt feeder to coating, dilute phase conveying of mash, a sifter for removing extraneous materials, milling to reduce material size, dry ingredient mixing, low pressure continuous dense phase conveying of finished kibble to packaging, or a general fugitive dust collection system – we have the right solution to meet your specific needs.



We work with pet food manufacturers of all sizes in markets worldwide, from low-volume specialty producers with complex needs to companies producing tons of product every hour.

We cover all steps for producing pet food:

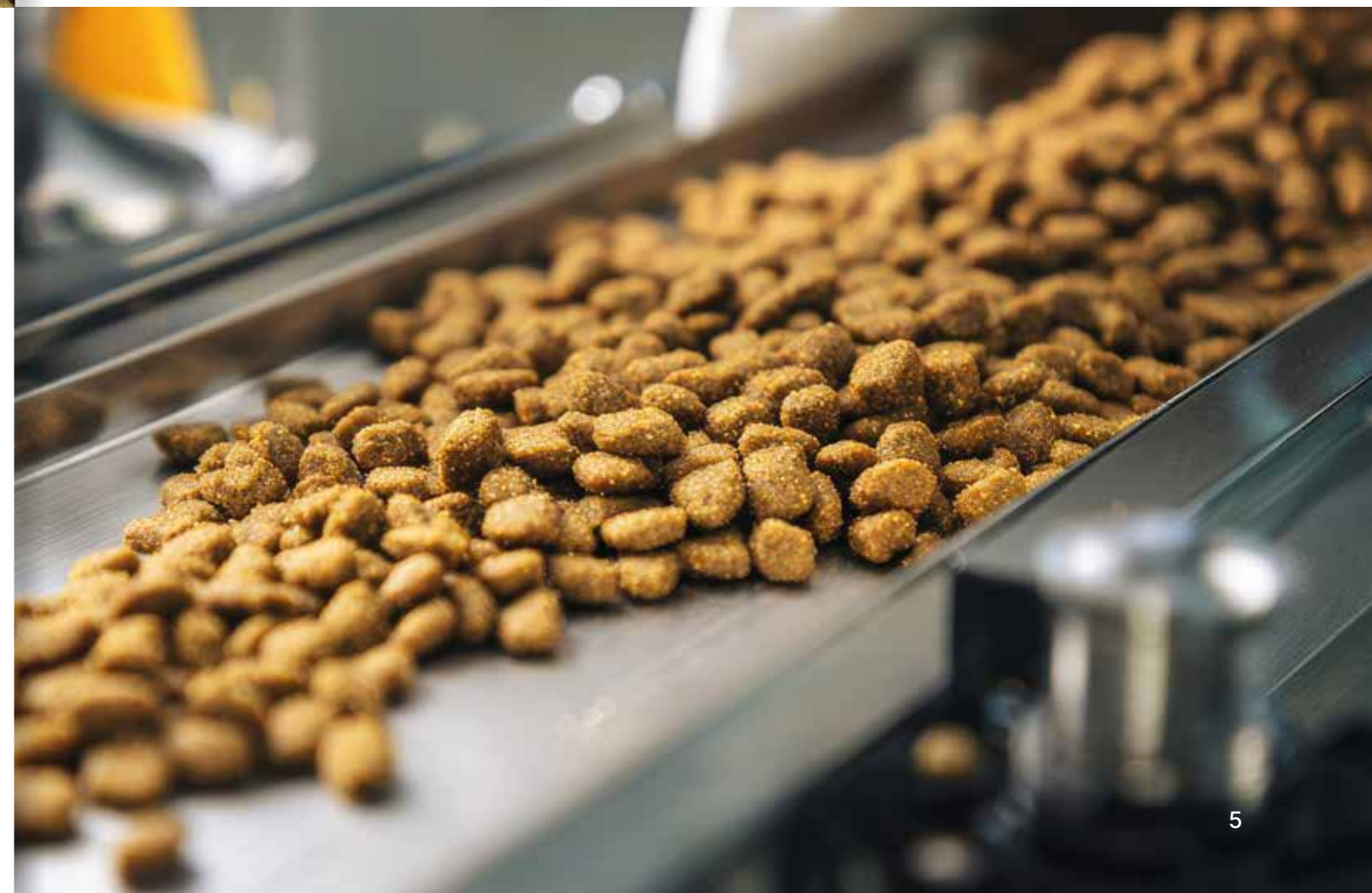
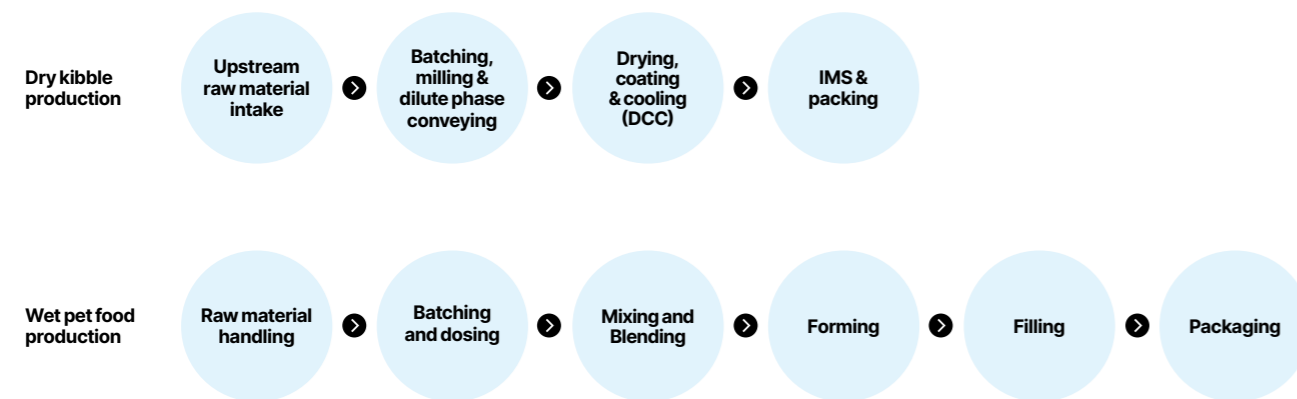

Turnkey process solutions for pet food (continued)



Project Management

At Coperion, everything we do is centered on customer satisfaction. We strive to make your equipment and systems robust and efficient.

Our project management teams become an extension of your business with a direct line of communication to the many resources within the Coperion global network. Your Coperion team will take command of the design/build process from the project kick-off all the way to process commissioning.

From start to finish, our teams are dedicated to meeting your business goals.

Process Controls

Our Process Controls Group has been entrusted to control processes for some of the world's most recognizable brands. We've been building customized controls for over 50 years and our engineers have an intimate knowledge of industrial processing and production. Our in-depth experience provides field proven solutions.

We can custom design whole-plant or partial systems for new plants or integrate legacy control systems. We make everything from small independent panels to complex multi-processor and distributed I/O control systems. Interface with warehouse management, MES and ERP software systems provide a seamless transfer of data throughout a facility.

The Coperion Controls Group forges long term relationships with customers to support large control system implementations, typically utilizing remote access tools allowing rapid resolution of issues or minor operational adjustments. From analysis and planning, through equipment and control panel design, to testing and long-term service, our customers work with a single point of contact throughout the project.

Coperion delivers custom-designed and engineered solutions for the following applications:

- Plant controls systems
- Truck or railcar loading, unloading and bulk storage systems
- Ingredient unloading, cleaning and storage systems
- Liquid storage, scaling and transfer systems
- In-plant transfer for major, minor and micro ingredients
- Dry ingredient convey systems
- Batch and continuous feeding systems
- Sifting, storage and mixer transfer systems
- Dust collection

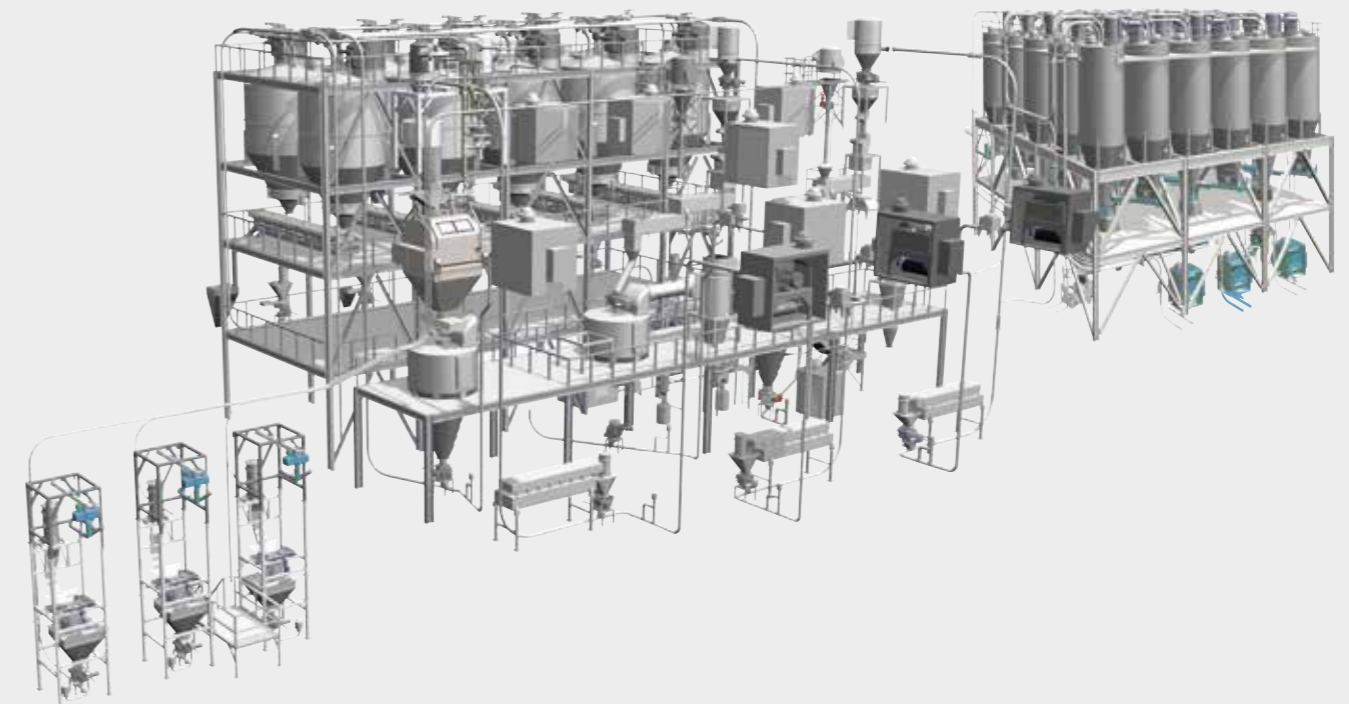

End product capability at a glance

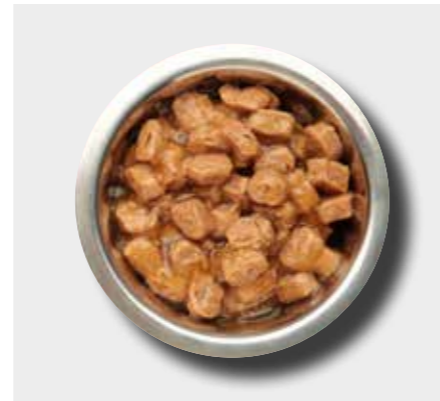

Coperion integrated systems deliver versatile production capabilities for pet food and fish pellets.

Our comprehensive range of solutions provides pet food manufacturers with an exceptional level of accuracy, consistency, and control when producing kibble for a wide variety of pet foods.

By seamlessly integrating advanced feeding, dosing, extrusion, drying, and handling technologies, we deliver a fully connected production system that operates smoothly from start to finish. This unified approach not only ensures reliable, repeatable performance across every batch, but also maximizes throughput and efficiency – empowering manufacturers to maintain superior product quality while optimizing overall operational productivity.

Dry pet food



Conventional kibbles



Coated kibbles



Functional or specialized kibbles



Food topper powders

Wet pet food



Wet meat chunks



Shredded wet food



Semi-moist kibbles

Fish feed



Floating fish pellets



Sinking fish pellets



Fish meal

Above are just a selection of the products our technology can produce – we can also create custom solutions tailored to your needs

Our test & innovation centers

Turn your ideas into high-quality pet food with confidence at Coperion's Test & Innovation Centers. Trial new recipes, gather real data, and walk away with a reliable scale-up plan – before making major investments.

What can you do here?

Trial new recipes

Experiment with new pet food recipes through real-world equipment testing – before you commit to full-scale production.

Optimize throughput rates

Go from lab-scale to product scale with proven scale-up methods, so your plant start up meets yield and quality targets.

De-risk equipment selections

Test proposed feeding, conveying and material handling equipment with your own ingredients.

Bring your team

Hands-on sessions, safety and operator training, and live reviews with our engineers, confidentially and securely.

See the full range of Coperion pet food technologies in action

Our experts can demonstrate how our equipment integrates seamlessly into your production process.

Ingredient handling & preparation

Accurate, gentle handling of the pet food ingredients for feeding applications.



Pneumatic conveying

Test your pet food kibble in our continuous dense phase conveying systems and confirm gentle handling and less product breakage.

Controls, data & service

Trial our Connect platform capabilities to monitor performance, build predictive maintenance routines, and turn test data into production KPIs. Continue with aftermarket packages tailored to your line.

Why pet food teams choose Coperion test centers

Speed to certainty:

Answer formulation and process questions in days-not months of plant trials.

Process and equipment expertise:

Direct access to specialists in feeding, conveying, and automation – working as one team.

Real-world proof:

Test on hygienic, production-representative assets with verified scale-up.

Confidential by design:

Controlled access, secure handling of proprietary formulations, and a clear data custody process.

Ready to see your next pet food win before it hits the line?

Tell us what you want to test. We'll assemble the right process, run the trials with your team, and hand you a validated path to scale. Book a trial today, email: fhn-info@coperion.com

Systems & ingredient automation

We supply a wide range of bulk and liquid material handling solutions including sifting, feeding, weighing, pneumatic conveying, extrusion, screening, filtration, bulk bag unloading and storage.

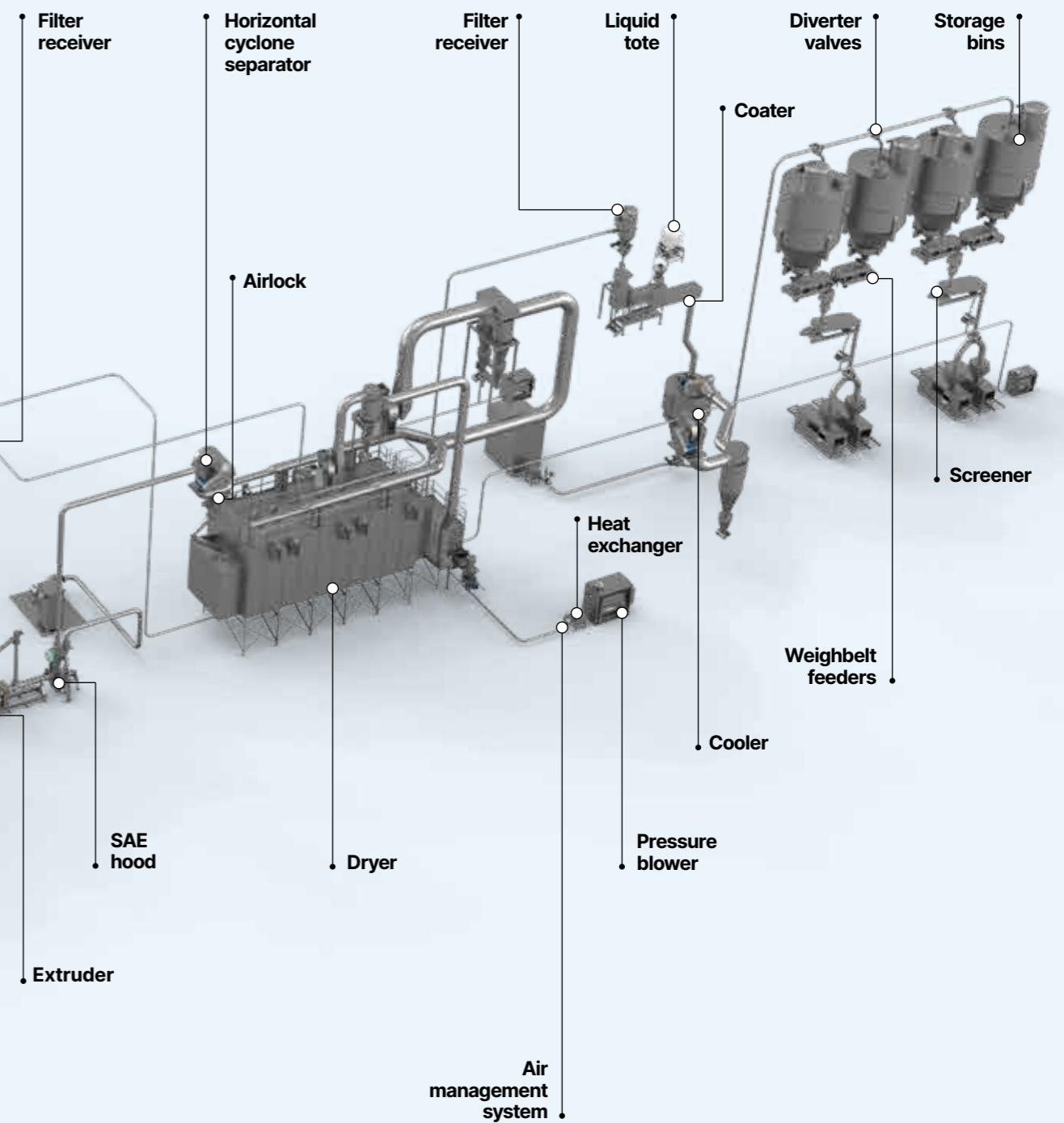
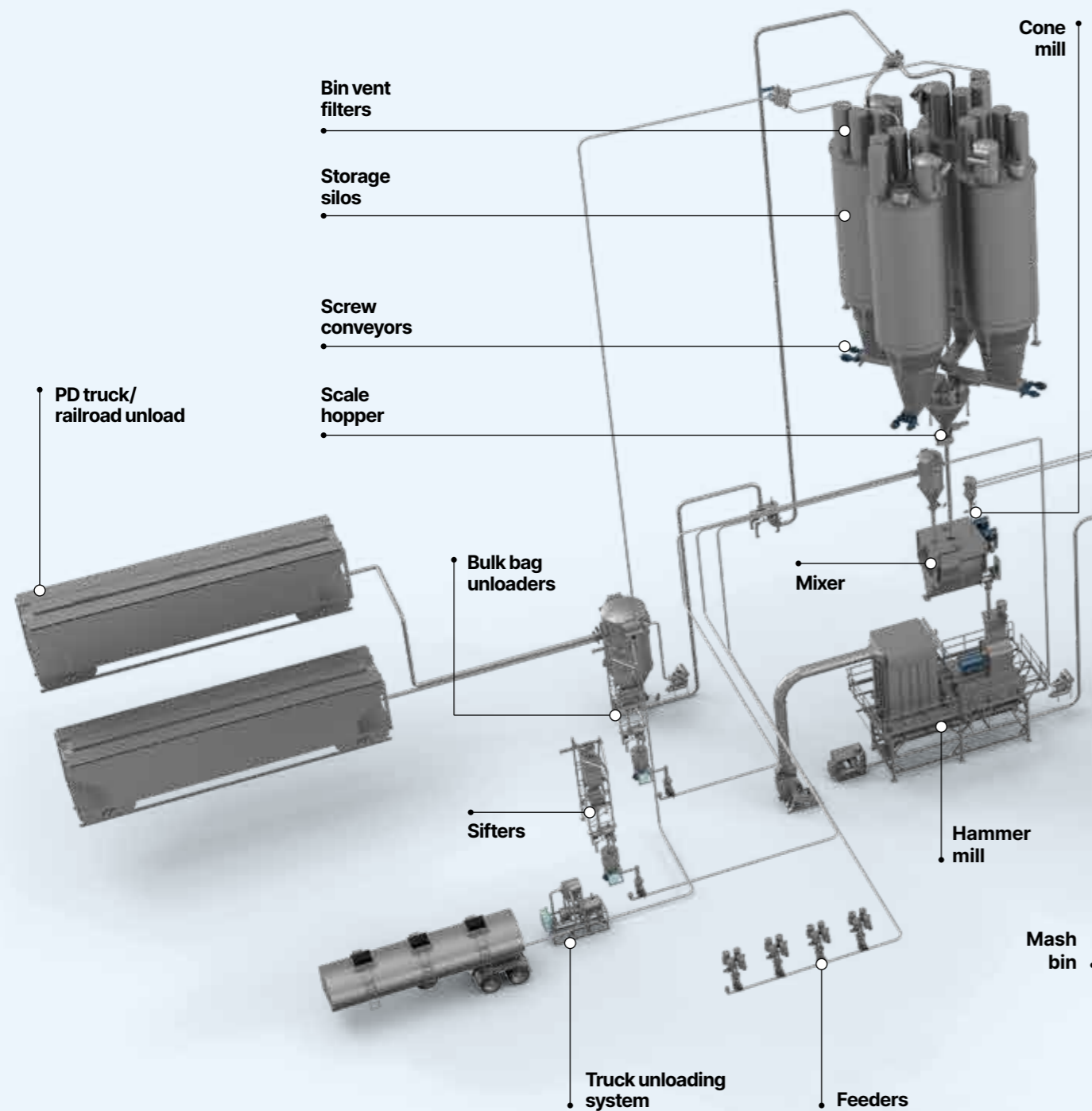

Material handling systems



For over 50 years Coperion has supplied the most recognized pet food brands throughout the world with state-of-the-art dry bulk material handling systems.

Coperion offers a comprehensive range of technologies, including pneumatic conveying, weighing, feeding, metering, extrusion, milling, sifting, and dust collection. With extensive experience in pet food manufacturing, Coperion engineers collaborate with customers to design efficient systems that ensure reliable and effective handling of ingredients throughout the production process.

Bulk Bag Unloaders

Coperion offers a modular bulk bag discharge system that provides flexible positioning to meet many process requirements. A two-paddle agitation system eliminates material bridging and promotes full bag emptying.



Pneumatic Conveying

Low pressure continuous dense phase conveying systems provide gentle handling of kibble. The conveying system induces materials through the convey line in slug form reducing product degradation.

With fewer fines the opportunity for product loss and contamination are greatly reduced.



Sifting

Kemutec sifters are designed to remove oversized clumps and deliver a uniform particle size. They efficiently eliminate unwanted materials such as strings, packaging fragments, insects, and other contaminants. Tool-free removal of the sifting screen, screen retainer, and paddle/blade assembly simplifies maintenance and minimizes downtime.



Dust Collection

Coperion has a wide range of filtration products for pet food processes. One application includes the design of filter receivers at the end of a pneumatic conveying system for separating product being conveyed from the convey air. Extensive bag and cartridge filtration products are also available for reducing the amount of fugitive fines accumulating throughout the factory.



Material handling systems (continued)



Our unloading, storage, and silo inventory solutions ensure efficient ingredient handling, accurate tracking, and reliable delivery.

Unloading and Storage

We transfer ingredients from railcar, bulk truck, or sacks into a variety of storage vessels that include silos, use bins, and hoppers. We specialize in bulk material handling equipment, so you can bet we have the right tools to unload and store your ingredients. We can then deliver ingredients to your warehouses at a time that is convenient for you.

Silo Inventory

Our Inventory measurement systems deliver a range of accuracy levels to meet diverse operational requirements. We utilize multiple sensing technologies – including load cells (strain gauge-based), ultrasonic sensors, capacitance probes, and point level devices – to provide reliable and application-specific measurement solutions.

Extrusion

Coperion's twin screw extruders deliver precise and reliable processing conditions for a broad spectrum of pet food formulations, from standard kibble to more specialized products. Their high screw speeds and robust torque capabilities ensure uniform cooking, optimal mixing, and consistent product quality, even at elevated throughput rates. This results in efficient, repeatable production with excellent control over texture and density.

When integrated with the Extruder Negative Airlift System, the process is further enhanced by safely conveying extrudate from the extruder to the dryer using HEPA-filtered or otherwise treated convey air. This controlled transfer not only improves hygiene but also minimizes the risk of airborne contaminants from the extruder room environment impacting the product. Together, these technologies support a cleaner process, improved product integrity, and greater overall operational efficiency.



Material handling systems (continued)

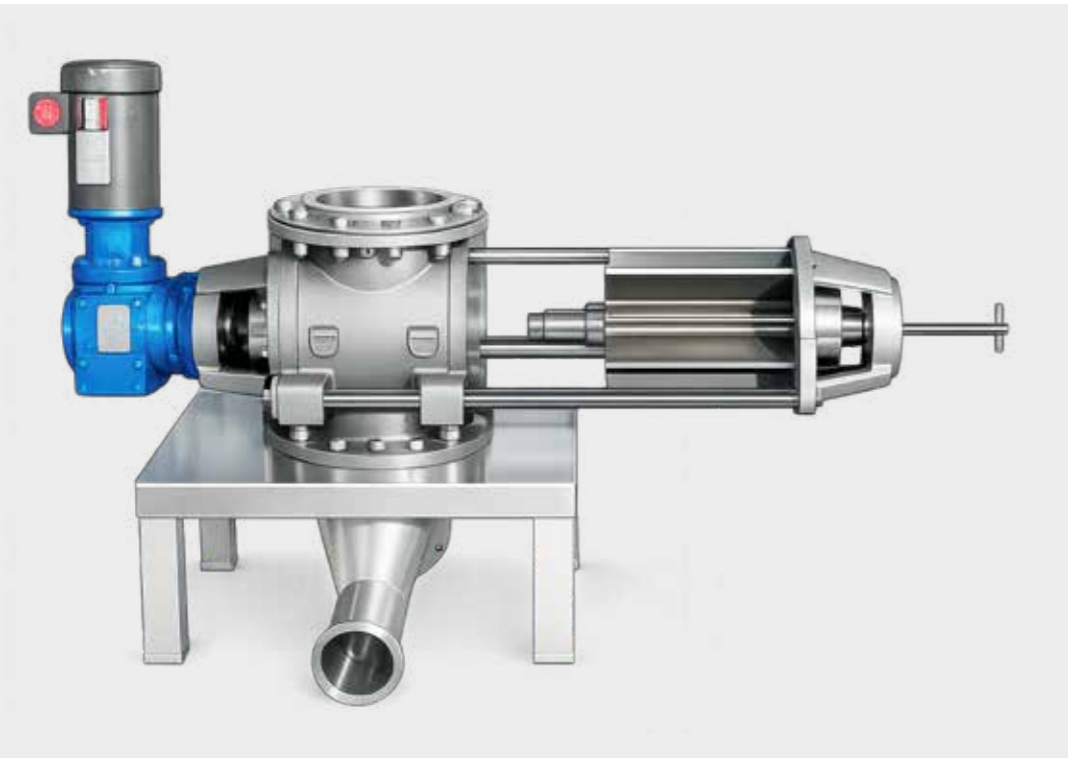

Horizontal Material Separator (HMS) Cyclone

The Horizontal Material Separator (HMS) cyclone is designed to efficiently separate conveyed material from the airstream. Engineered for hygienic processing environments, the HMS features smooth, ground interior product-contact welds and continuous exterior welds that are thoroughly cleaned of slag and splatter.

Compared to conventional separators, the HMS offers a reduced vertical footprint, making it easier to integrate into existing systems. Its streamlined design also simplifies cleaning and maintenance, improving overall operational efficiency.

The HMS is well-suited for handling a wide range of products, including large and small kibble, large flakes, and fish feed.



Our hygienic airlocks, separators, and liquid systems support high-rate, sanitary processing for demanding applications.

Airlocks and Diverter Valves

A wide range of hygienic airlocks are available for applications involving dry raw or finished products where frequent inspection and system clean-out are essential. Designed to support high process rates, these airlocks are ideal for demanding pet food processing environments.

Our diverter valves are engineered to prevent contamination while enabling efficient line switching for both dilute and dense phase conveying systems.



Liquid Handling

The Coperion IBC liquid tote system is a sanitary transfer system designed for hygienic, uninterrupted liquid ingredient handling. Ideal for managing oils, palatants, and vitamins, it ensures seamless tote changeovers without halting production.



Material handling systems (continued)

No Ledge Couplings

The Coperion No-Ledge Coupling is engineered for pet food and light industrial conveying applications where fragile materials and hygienic standards are critical.

Unlike traditional compression couplings, which are prone to pipe misalignment during installation, the No-Ledge Coupling forms a precision machined, tolerance-controlled joint. This guarantees proper alignment and creates a completely ledge-free interior at connection points. The result is reduced friction, fewer product traps and crevices, and significantly less fines generation – helping maintain product integrity and hygienic system performance.



Weighing and Feeding

A weighbelt feeder introduces dried kibble into continuous enrobbers to coat it with fats, oils, and dry palatants. Once transferred from the weighbelt, Coperion screw feeders apply the dry palatant. A loss-in-weight screw feeder is typically used, as the amount of palatant added is easily measured and controlled. For drum-style enrobbers, the feeder includes an extended discharge tube to reach the drum, with adjustable slot openings to help distribute the dry digest onto the tumbling kibble bed.



Cleanable Rotary Pocket Feeder

For efficient discharge of granular materials from hoppers, bins, silos, or cyclones, the Coperion Cleanable Rotary Pocket Feeder offers the perfect solution. Its hygienic, quick-clean design minimizes downtime and maximizes operational efficiency. When used in blending processes, it can replace mechanical mixers, preventing excessive product breakage and preserving product integrity.

Depositing

Unifiller depositing systems provide accurate portioning for wet pet food products such as smooth or chunky pâté, morsels, and gravy. These systems ensure consistent filling into a wide range of containers while maintaining product integrity. By automating the depositing process, manufacturers can simplify and accelerate pet food packaging operations, improving efficiency, reducing waste, and ensuring reliable portion control.



Aftermarket sales & services



Connect Advisor is Coperion's integrated technology platform, developed to enhance visibility, performance, and lifecycle management across industrial processes and equipment.

Connect Advisor

At Coperion, we've been working to reshape how industrial processes and the equipment that powers them are managed, through ongoing development of our Connect technology platform.

With solutions that leverage Connect Advisor, you can:

- Gather data that can be used to optimize process performance
- Monitor equipment condition and performance in real time
- Leverage information to enable proactive preventive maintenance
- Enable effective, efficient remote assistance and service
- Identify opportunities to improve processes through engineering and operational enhancements
- Generate actionable analytics about duty cycles, energy usage, throughput and more

Complete after-sales solutions

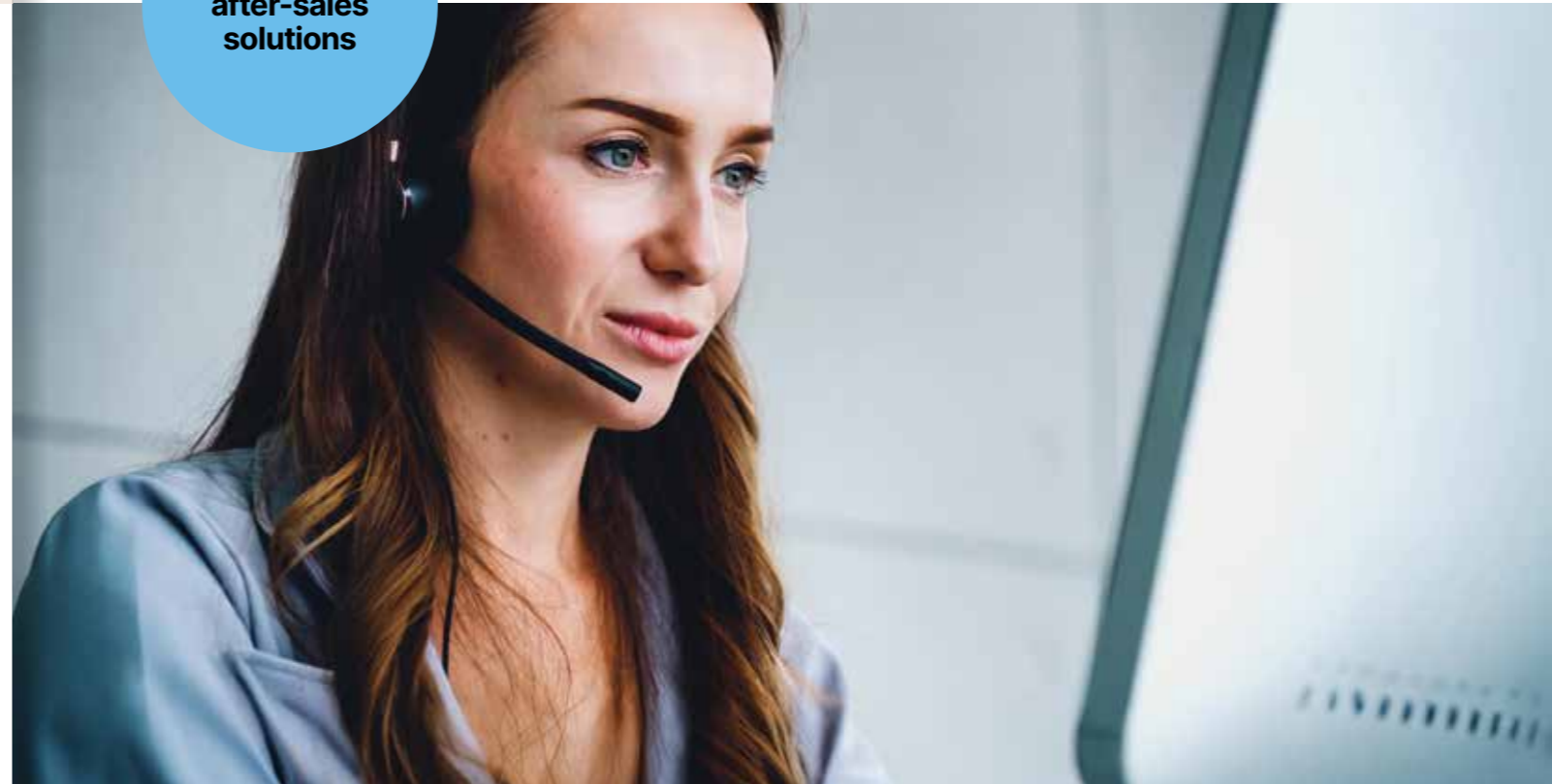

Looking for after-sales solutions? Our extensive Aftermarket program provides you with after-sales services – customized to your specific requirements.

The framework of our Aftermarket program is designed with you in mind. With the guidance of our experienced after-sales team, you can create Aftermarket packages comprised of original spare and wear parts, various services and high-quality components to meet your needs.

Our Aftermarket program is based on a modular principle – you can pick and choose any individual product or a combination thereof. Aftermarket service categories focused on repair, inspection, management and support help to easily find the appropriate products.

We welcome the opportunity to provide you with individual consultation, either as part of an Aftermarket contract or on an individual basis. Whatever full service means to you – let's create it together!



For technical information,
scan the QR code

E: fhn-info@coperion.com

W: coperion.com/fhn

Follow Coperion Food, Health & Nutrition



B-650201